

Physical Testing of a Stepped Masonry Spillway

P. D. DOWN, Mott MacDonald-Bentley, Leeds, UK

M. WEARING, CRM Rainwater Drainage Consultancy, Bolton, UK

SYNOPSIS Many of the dams that have been constructed in the UK incorporate stepped masonry spillways. In recent years, a number of incidents have highlighted the risk of damage to these types of spillways during flood events resulting in a potential risk to reservoir safety. This was particularly evident during the incidents at the Boltby and Ulley reservoirs.

Following these incidents there has been particular emphasis placed on reviewing the ability of stepped masonry spillways to safely convey the design flood event. In many cases this has resulted in works to substantially improve or replace the existing spillway facilities.

Mott MacDonald Bentley (MMB) is employed by Yorkshire Water to undertake reservoir improvement projects on their behalf. During a recent project investigation works were carried out at a Yorkshire Water reservoir to prove the structural condition of the existing spillway and its ability to withstand the affects of flood flows along it. The aim was to provide an efficient solution for the required spillway improvements.

INTRODUCTION

The reservoir considered in this paper is operated by Yorkshire Water. Construction was completed in 1926. The dam comprises a 39m high, earth-fill embankment incorporating berms to the downstream face and, in particular, a large, extended berm at the toe. A masonry overflow weir is located on the left-hand bank with a stepped spillway, formed from sandstone, running along the left-hand mitre. On the line of the embankment crest a double-arched masonry bridge crosses the spillway.

The spillway has a total length of 376m. It varies in width from 21m to 15m and falls through a height of 34m. The spillway is formed by 46 bays separated by steps. The bays tend to decrease in length and increase in gradient with distance downstream. The lower section incorporates a steep, stepped cascade incorporating flights of up to four steps at a time with a gradient of up to 1 in 1.9.

DAMS: ENGINEERING IN A SOCIAL & ENVIRONMENTAL CONTEXT

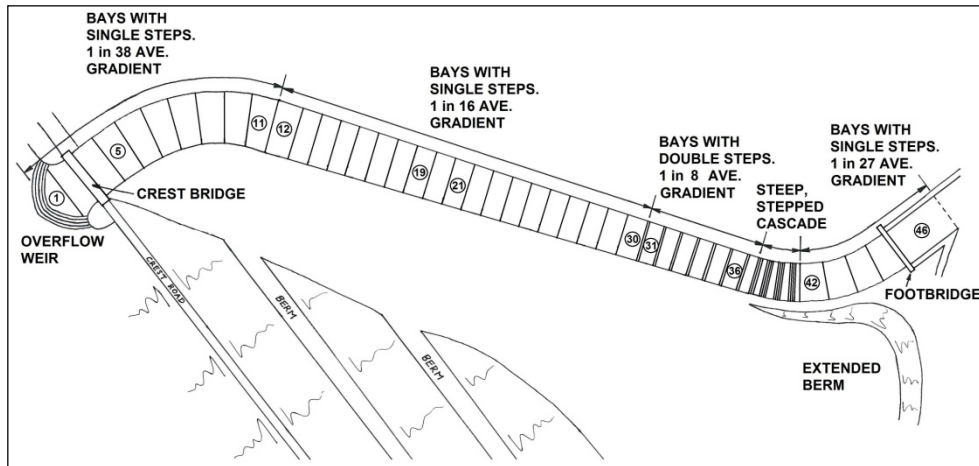

Figure 1. General arrangement of spillway

Following a recommendation made by the Inspecting Engineer, studies by MMB, including a physical model of the spillway produced by CRM Rainwater Drainage Consultancy, have been carried out to determine the improvement works required. In addition, MMB and their sub-contractor, ESG/PMC, performed physical investigations of the existing spillway to prove its structural integrity.

This paper describes the investigations performed at the spillway, summarises the findings and details the implications on the improvement proposals and how this could influence other similar projects.

ASSESSMENT OF PRESSURES AND PHYSICAL MODELLING

Guidance was issued by Defra/Environment Agency in 2010 relating to the design and maintenance of stepped masonry spillways. This identified the following types of flow that can occur along spillways:

- Nappe flow
- Transitional flow
- Skimming flow

During the design flood event, a skimming flow regime is likely to be present along the upper section of the spillway. Along the steep, stepped cascade at the downstream end, nappe flow conditions are present.

An estimate of the pressures that may occur within the spillway was required. Section 3.7 of the Defra/Environment Agency guidance provides a method to estimate pressures during nappe flow conditions as determined by Chanson (1994) and May & Willoughby (1991). This was used to estimate the pressures at the downstream section of the spillway where the greatest risk was perceived (Table 1).

Table 1. Estimated pressures using nappe flow calculation method

Description	Bays 29-30	Bays 36-37	Bays 40-41
Mean flow depth (m)	1.97	2.00	2.18
Mean velocity (m/s)	14.8	16.0	17.0
Mean pressure (kN/m ²)	3.8	4.4	4.4
Pressure – upper limit (kN/m ²)	102.3	119.6	134.4
Pressure – lower limit (kN/m ²)	-61.9	-72.4	-82.3
Pressure difference (kN/m ²)	164.3	192.0	216.8

In an attempt to further estimate the pressures within the spillway the 1:30 scale physical model built to determine the spillway operation also incorporated pressure tapping points at Bay 36 (Figure 2). It was recognised that, due to the small scale of the model, the ability to accurately establish the peak pressure changes on the step was likely to be limited. The maximum pressure difference recorded and scaled from the model was equivalent to just over 5m head of water (49kN/m²). The pressures recorded for the 0.5 PMF model flow were very similar.

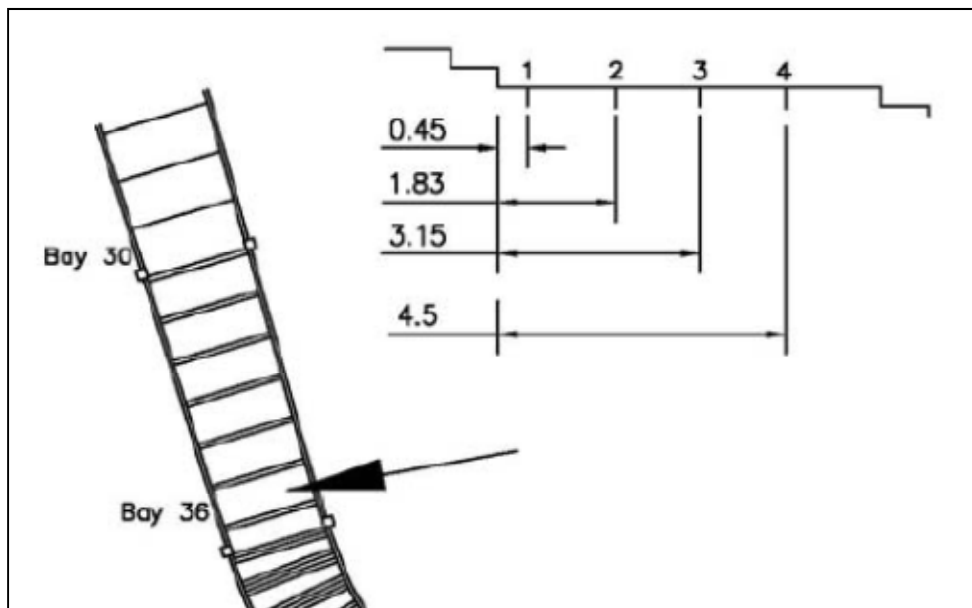

Figure 2. Pressure measurement locations in physical model

The estimated pressures obtained by theoretical calculation and the physical model results are markedly different. Test carried out by CRM as part of the Defra/Environment Agency study showed that low and high pressure areas could be very localized. To ensure these are picked up, a large number of pressure tapping locations would be required. This was not practical on a small scale model constructed for the broader purpose of assessment of the overall chute hydraulics.

INSPECTION OF EXISTING INVERT

A visual inspection of the spillway invert was carried out to assess the general condition of the mortar joints between the masonry blocks. Detailed measurements of the missing/eroded joint mortar were recorded for bay 19, located approximately mid-way along the spillway, and bay 42 located at the downstream end.

The joints in the upstream section of the spillway invert (bays 1-12) appeared in good condition. Much of the mortar between the spillway blocks appeared to be in very good condition. The missing/eroded mortar that was present was minor and restricted to small, isolated locations.

Along the middle, straight section of the spillway, the joint erosion increased only slightly. This was usually up to 50mm although erosion depths up to 90mm were occasionally recorded. The missing/eroded mortar tended to occur in the joints aligned in the direction of flow. The greatest depths, up to 130mm, were present in the joints of the steps between bays.

Table 2 summarises the estimation of missing/eroded mortar in the upper and middle sections of the channel invert.

Table 2. Estimate of joint erosion between invert blocks (bays 1-30)

Joint erosion depth range (mm)	“Average” erosion depth (mm)	Length of affected joints (m)	Proportion of total length (%)
<=25	25	10,531	89
25-50	35	974	8
50-100	75	338	3
>100	150	0	0

At the downstream section of the spillway erosion of the mortar joints was more apparent. This was particularly evident in the vicinity of the step, stepped cascade due, presumably, to the increase in velocities, energy and turbulence of the flows.

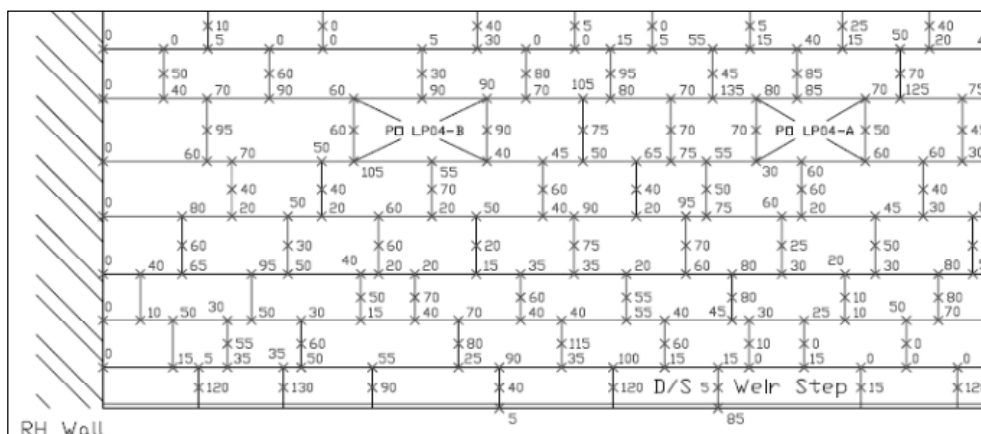

Figure 3. Depths of missing/eroded joint mortar at bay 42 (in mm)

DOWN & WEARING

At bay 42, immediately downstream of the cascade, the missing/eroded mortar appeared the most extensive with depths up to 100mm being common and up to 180mm occasionally recorded (Figure 3). Within this bay, some areas appeared to suffer greater erosion than adjacent sections. This may be indicative of differing mortar batches used during construction. Much greater depths, occasionally in excess of 300mm, occurred at the joints in the steps at the ends of the bay.

LOAD TESTING OF SPILLWAY INVERT

The channel invert comprises sandstone masonry blocks, up to 380mm thick, constructed upon a concrete bed of similar thickness. The weight of the blocks was approximately 8.8kN based on a 1m² invert area.

To help estimate the ability of the spillway channel to resist the effect of flows along it, on-site physical testing was undertaken. This comprised in-situ load testing of the channel invert blocks to assess the strength of the bond to adjacent blocks and the concrete bed beneath.

Figure 4 shows the test equipment used. Anchor dowels were fixed into the invert block to be tested and these, in turn, were attached to a load plate and shaft. A hydraulic ram, supported by a beam spanning the test block and adjacent blocks, gradually imposed a load. The applied load and movement of the test block and adjacent blocks was monitored throughout the test.



Figure 4. Equipment for load testing of channel invert blocks

DAMS: ENGINEERING IN A SOCIAL & ENVIRONMENTAL CONTEXT

Test locations LP01-A to LP04-A were situated progressively downstream along the length of the spillway. These were chosen to be representative of the existing block condition at their respective locations. The test block size and the missing/eroded mortar around the perimeter were recorded prior to testing. Test locations LP05 and LP06 were located within the same bays as LP01-A and LP04-A respectively. For these two blocks, the mortar in the side joints was saw-cut to full depth so that the bond of the block to the concrete bed could be tested independently.

At locations LP01-A and LP02-A, a test load of 400kN was achieved without failure of the invert. Movement of the test blocks in excess of 0.1mm was noted to commence at a load of 190kN at LP01-A and 220kN at LP02-A. The test block movement at LP02-A, under a load of 400kN, was only 0.29mm. At LP02-A, the maximum test load was increased to 503kN still without failure. Maximum vertical movements of 0.86mm and 1.12mm were recorded at LP01-A and LP02-A respectively with smaller movements noted in the surrounding blocks.

At locations LP03-A and LP04-A, the extent of missing/eroded mortar at the side joints was generally greater than at the previous test locations. During load testing, failure of the test blocks was recorded at 431kN and 420kN respectively. At LP03-A, the test block failed in tension. The section into which the dowels were fixed separated from the rest of the block which remained in-situ (Figure 5a). For LP04-A, the test block split apart around the dowels resulting in failure of the dowel bond to the stone (Figure 5b).



Figures 5a & 5b. Failed blocks at test locations LP03-A and LP04-A

Movement of the test blocks in excess of 0.1 mm was noted to commence at a load of 221kN at LP03-A and 201kN at LP04-A. At LP03-A, a gradual vertical movement was noted up to a load of 420kN before significant failure of the test block occurred (Figure 6). The results for LP04-A were more difficult to interpret. However, a 1.02mm vertical movement of the test block was recorded at 400kN before failure of the dowel bond to the block occurred. In both cases, corresponding displacements were noted in the adjacent blocks during the movements at the test block.

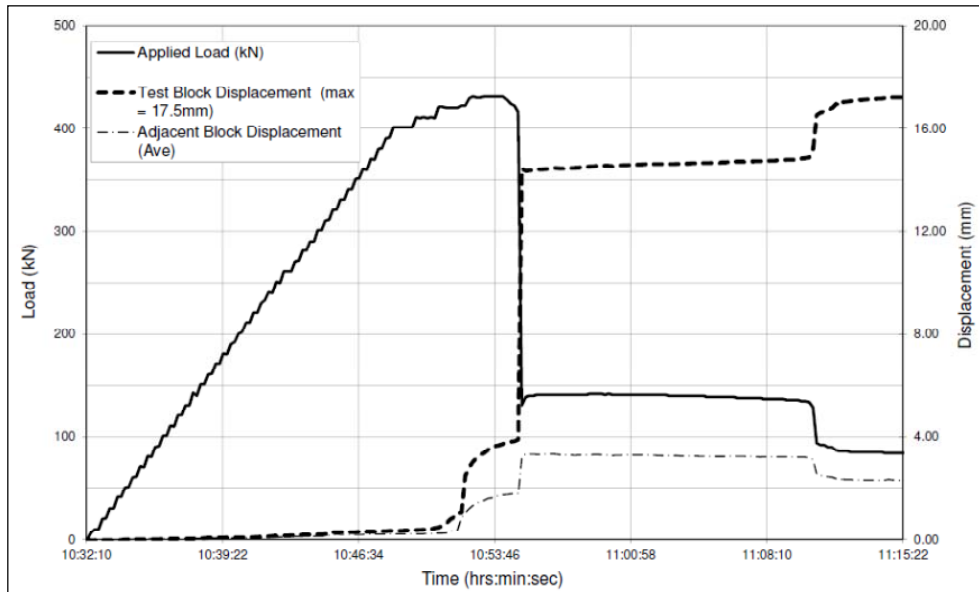
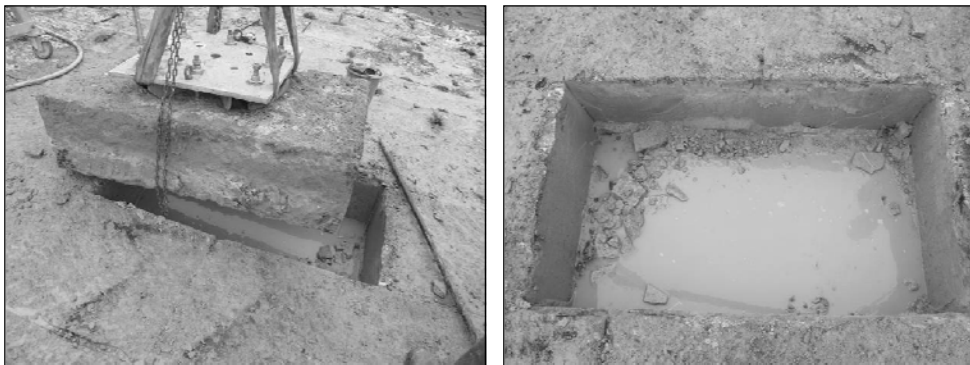

Figure 6. Load test results for block ref. LP03-A

At test locations LP05 and LP06 the blocks were restrained by their bond to the concrete bed alone. Test block failures were recorded at 181kN and 192kN respectively. Inspection of the blocks and the remaining void indicated a relatively clean failure plane (Figures 7a & 7b). This appears to indicate failure of the mortar bonding the block to the bed.



Figures 7a & 7b. Extracted block at test location LP05

The load was progressively applied until a sudden movement of the block occurred, in both cases, before the block had deflected by 0.1mm. The load test results for location LP05 are given in Figure 8.

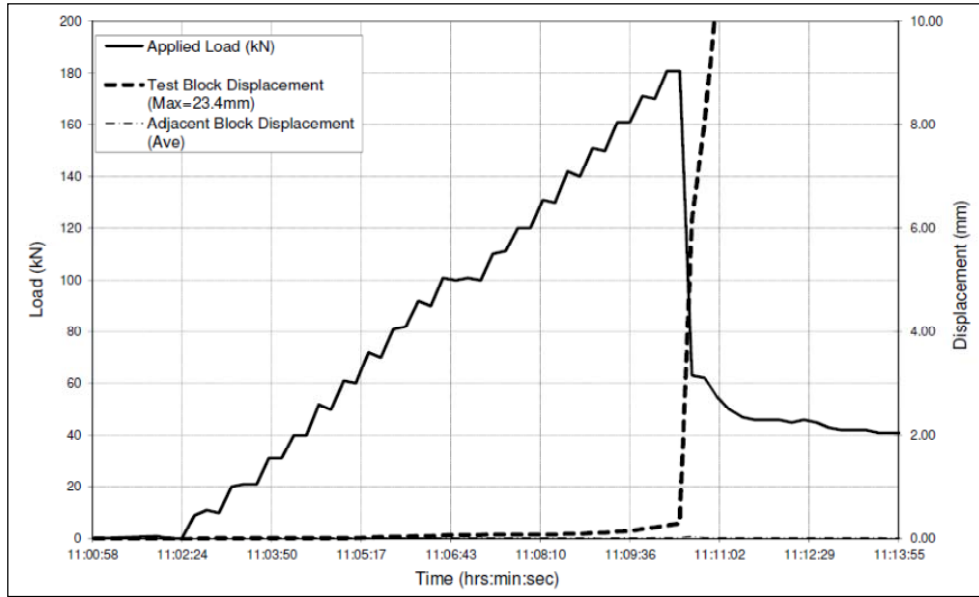

Figure 8. Load test results for block ref. PO LP-05 with saw cut joints

The results of the invert block load testing at the various locations along the spillway are summarised in Table 3.

Table 3. Summary of masonry invert block load test results

Test Location Ref.	Block Dimensions (m)	Block Top Surface Area (m ²)	Block Volume (m ³)	Maximum Test Load (kN)	Deflection or Block Failed?
LP01-A (Bay 21)	1.45 x 0.74 x 0.38 deep	1.073	0.408	400	0.86mm Adjacent blocks also deflected
LP02-A (Bay 30)	1.35 x 0.71 x 0.36 deep	0.959	0.345	503	1.12mm Adjacent blocks also deflected
LP03-A (Bay 36)	0.97 x 0.71 x 0.35 deep	0.689	0.241	431	Failed. Masonry block failed in tension and split
LP04-A (Bay 42)	1.22 x 0.71 x 0.38 deep	0.866	0.329	420	Failed. Masonry block cracked and dowels pulled out
LP05 (cut) (Bay 21)	1.37 x 0.76 x 0.38 deep	1.041	0.396	181	Failure of masonry block / mortar bed interface. Block extracted intact
LP06 (cut) (Bay 42)	1.09 x 0.71 x 0.38 deep	0.774	0.294	192	Failure of masonry block / mortar bed interface.

ASSESSMENT OF CHANNEL WALL

Visual inspection of the masonry spillway walls indicated these to be in very good condition with no obvious signs of erosion or distress. The joints

between the masonry blocks appeared of a high standard being both tight and even. Weepholes are present at regular intervals along both walls.

A section of the existing spillway wall to the left-hand side of the channel was dismantled to prove the overall construction and structural integrity. It was found to be of typical construction for the period comprising masonry ashlar blocks forming the inner face backed with concrete (Figure 9). Behind the wall is a granular backfill which provides a drainage function. The wall was dismantled with some difficulty and this further indicated the high standard of the original construction.

The investigation of the left-hand wall was supplemented with diamond drilled cores in the right-hand wall directly opposite. This indicated a similar type and standard of construction.

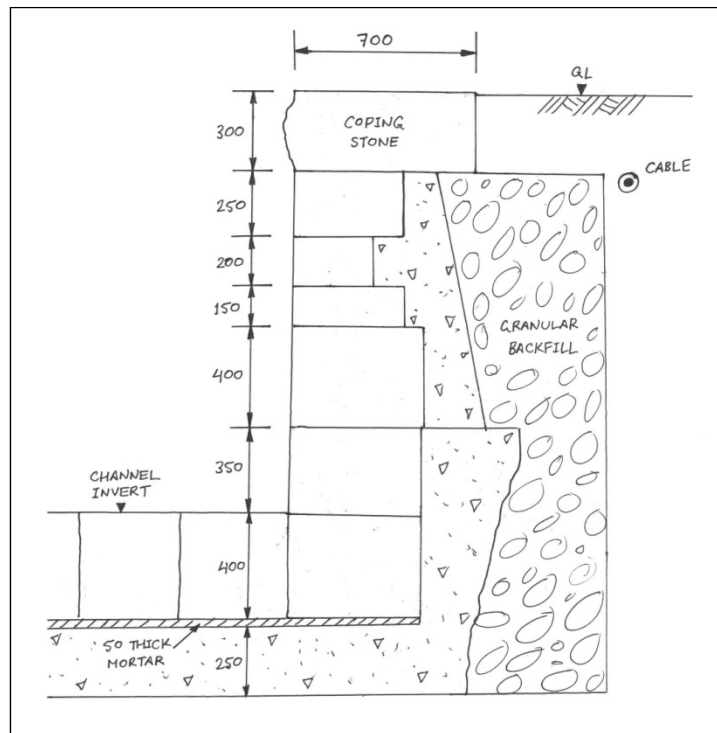

Figure 9. Section of left-hand spillway wall at investigation site

FINDINGS OF INVESTIGATIONS

In estimating the hydro-dynamic pressures that may be encountered within the spillway, significant limitations and differences were noted in the two techniques employed. Towards the downstream end of the middle straight section of the spillway, theoretical calculations indicated a maximum pressure difference of 192kN/m^2 whereas the physical model results indicated a possible pressure difference of around 49kN/m^2 . Whilst no definitive conclusion could be gained, the results did at least provide some indication of the scale of the forces that may occur.

DAMS: ENGINEERING IN A SOCIAL & ENVIRONMENTAL CONTEXT

At test locations LP01-A and LP02-A, the invert blocks withstood loads of 400kN and 503kN (equivalent to 372kN/m² and 525kN/m² based on the block surface area) respectively. A load of approximately 200kN appeared to be withstood before the bond with the concrete bed was broken and the masonry invert appeared to move as a whole.

At test locations LP03-A and LP04-A it was found that the tensile strength of the material forming the individual blocks could be more of a limiting factor particularly where missing joint mortar has reduced the bond to the adjacent invert blocks. Up to the loads where the sandstone block failure occurred (equivalent to 610kN/m² and 462kN/m² respectively), the channel invert appeared to behave in a similar manner to the previous test locations.

At test locations LP05 and LP06, failure of the bond between the test blocks and their bond to the concrete bed occurred at loads of 181kN and 192kN (equivalent to 174kN/m² and 248kN/m²) respectively. This seems to indicate an average bond strength of the blocks to the concrete bed of approximately 200kN/m². This also appears to correspond with the loads required to move the blocks in the previous tests by 0.1mm.

The methods of on-site load testing employed in the spillway invert may not be fully representative of the pressure distributions that may occur under hydro-dynamic conditions. However, the results provide an indication of the ability of the channel to withstand such pressures. Where there is no bond to the concrete bed or adjacent blocks, hydro-dynamic pressures during flood flows could be sufficient to remove individual masonry blocks from the spillway invert. A good bond to the concrete bed and adjacent blocks appears to be sufficient to withstand such pressures.

It was not practical to load test the blocks within the spillway wall. However, the results of the investigations undertaken appear to give similar conclusions to those for the base. The structural integrity of the walls could be compromised by overtopping of flood flows that may result in removal of the backfill material.

INFLUENCE ON PROPOSED IMPROVEMENT WORKS

Without the detailed knowledge of the spillway construction and its structural condition, a precautionary approach to the spillway improvements was initially proposed. This would have involved demolition of significant sections of the masonry spillway, where the hydraulic efficiency was more critical and the existing channel walls relatively tall, and replacing it with a new concrete channel. Elsewhere, the existing invert was to be overlaid and the walls lined and raised with a new concrete construction.

From the results of the subsequent investigations, the existing spillway is in generally good overall condition. It appears that flood flows could be safely conveyed providing that these flows are fully contained within the channel

DOWN & WEARING

and any areas of deterioration are remedied. At the downstream section of the channel, should any overtopping of the channel occur, overland flows are considered not to pose a risk to the embankment.

With the current knowledge, it has been possible to justify a more efficient scale of the improvement proposals and retain as much of the existing structure as possible. Improvement to the upper and middle sections of the spillway channel are now proposed comprising remedial works to the channel invert mortar joints and raising of the existing walls where required.

CONCLUSION

The results of the investigations undertaken suggest that stepped masonry spillways can, in suitable circumstances, satisfactorily convey flood flows providing the following is observed:

- The existing structure is in good structural condition.
- Flows are fully contained within the channel.
- Defects in the jointing are remedied to ensure satisfactory inter-block bonding and avoid the penetration of spillway waters.

Where improvements of stepped masonry spillways have been identified at other reservoir sites, suitable investigation may provide benefits and efficiencies by maximising the use of the existing channel and reducing the scale of any additional works required.

The authors would conclude that there is little benefit in attempting to gain hydro-dynamic pressure fluctuation data in stepped areas on cascades from a small scale model. A large scale section (minimum 1:10 scale) must be constructed and fitted with numerous pressure transducers to ensure reliable pressure data is collected.

The investigations have also identified a need for further research into hydro-dynamic pressures within spillways under skimming flow conditions particularly where flatter channel gradients are present, as is the case at many UK reservoirs.

ACKNOWLEDGEMENTS

The authors would like to thank Tim Dyke and Lindsay Deuchar, Yorkshire Water for their assistance during the preparation of this paper. Additional thanks are extended to Ian Carter from MWH, Tim Hill from Mott MacDonald and Ray Baker from CRM Rainwater Drainage Consultancy.

REFERENCES

Environment Agency (2009). *Bulletin No.1, Improving Reservoir Safety, Sharing Lessons Learnt, Vulnerability of Masonry Spillways.*
Environment Agency

DAMS: ENGINEERING IN A SOCIAL & ENVIRONMENTAL CONTEXT

Defra/Environment Agency (2010). *Guidance for the Design and Maintenance of Stepped Masonry Spillways, Project: SC080015*. Environment Agency

Chanson, H (1994). *Hydraulic design of stepped cascades, channels, weirs and spillways*. Elsevier Science Ltd., Oxford

May R.W.P. & Willoughby I.R. (1991). *Impact pressures on plunge basins due to vertical falling jets*. Hydraulic Research Report No.SR242, Wallingford.